

TECHNICAL DATASHEET



EF END CAP

00 Update - 05/2023

TECHNICAL DATA

Article No	001 117 2140 0032
d (mm)	32
D (mm)	45
L (mm)	63
le1 (mm)	54
m (mm)	17
Weight (Kg)	0,058
Box Quantity (pcs)	100
Box Dimension (cm)	35,5x35,5x26

INJECTION MOULDED

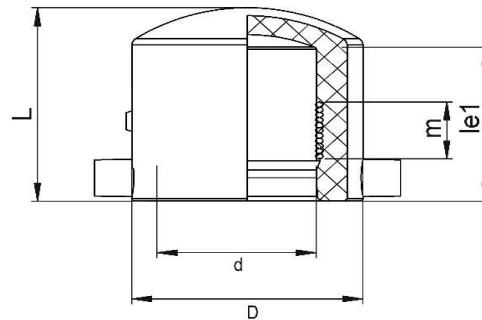

IDENTIFICATION OF PRODUCT

D(mm)	32
SDR	11
RAW MATERIAL	PE 100
PRESSURE CLASS	16 Bar Water 10 Bar Gas
TRADEMARK	NTG
EXECUTION	Injection Moulded
STANDARD	EN 12201-3 EN 1555-3 AS / NZS 4129
SPECIFICATION	Suitable for SDR9...11 pipe 4 mm pin connectors

EF SPECIFICATION

WELDING VOLTAGE	40V
RESISTANCE	11,00 Ω
WELDING TIME	45 Sec.
COOLING TIME	10 Min.
WINDING TYPE	Monofilar
WELDING BARCODE	



961420310322401105045119

Tolerance on diameters and thickness according to the standards. The other dimensions are specialized. Tolerance $\pm 5\%$. NTG PLASTIK reserves all the right to change any information without giving prior notice. The production, distribution and utilization of this document without explicit authorization is prohibited.

Fr 161 Rev 00